

Incarcare dinamica maxim 80 kg/panou
 Latime panou maxim 1250 mm
 Inaltime panou maxim 3000 mm
 Sticla 10 - 12 mm

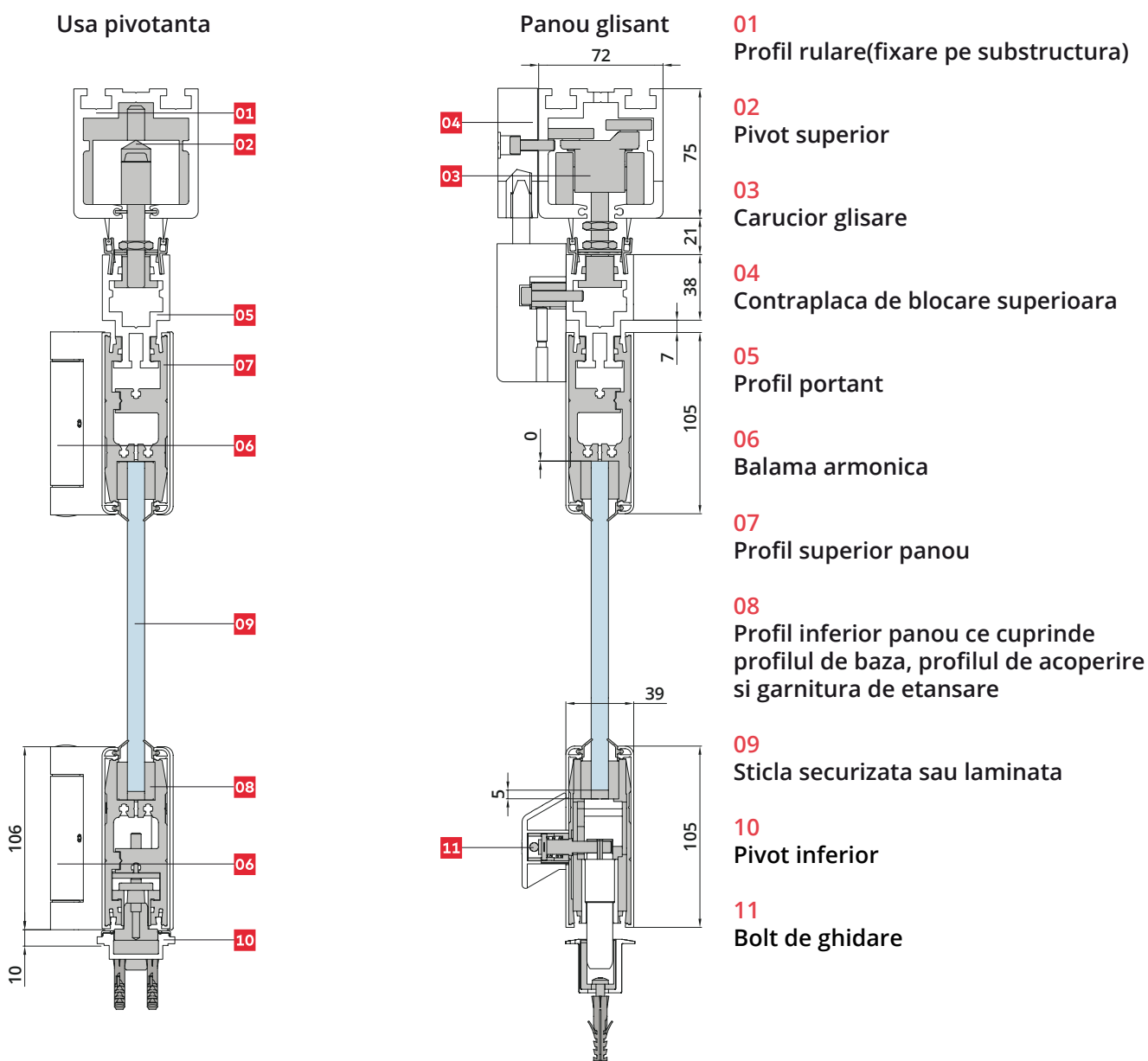

Sistem usa armonica FSW Easy Safe - detalii constructive si de montaj

Prezentare generala si dimensionala



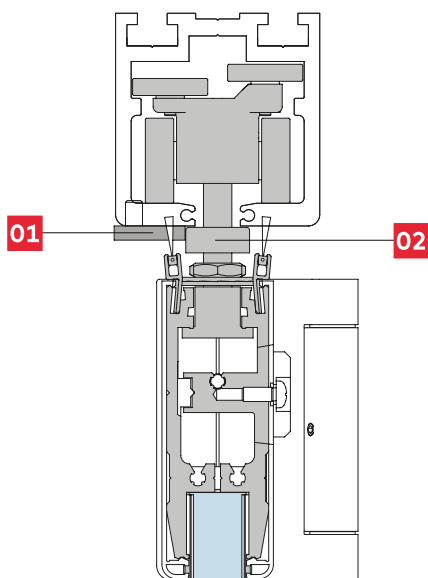
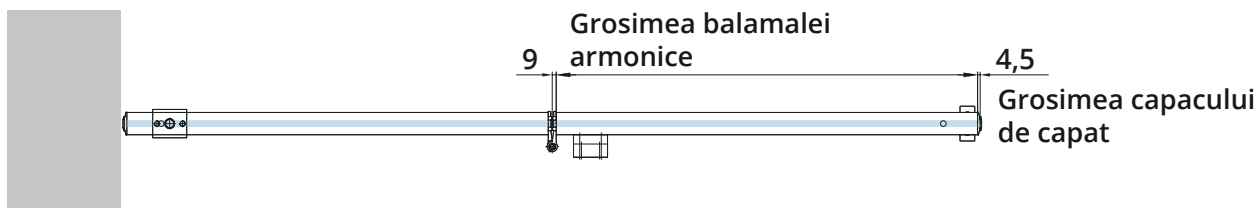

01
Placa de contact

02
Carucior glisare cu dispozitiv de oprire

Variante de executie

Tip 1

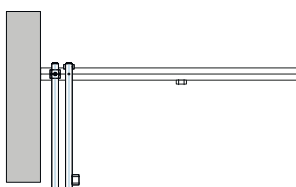
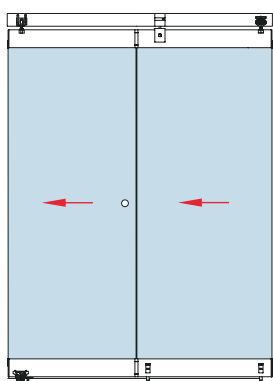

Tip 1a - 2 panouri stanga(ca in imaginea alaturata)

Tip 1b - 2 panouri dreapta

Tip 1c - 4 panouri(2 panouri stanga si 2 panouri dreapta)

Tip 2

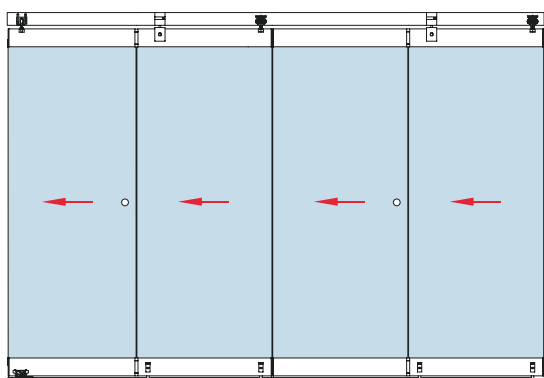

Tip 2a - 4 panouri stanga(ca in imaginea alaturata)

Tip 2b - 4 panouri dreapta

Tip 2c - 8 panouri(4 panouri stanga si 4 panouri dreapta)

*Distanta minima structurala(ex - balustrade, scari, etc)

Tip 3

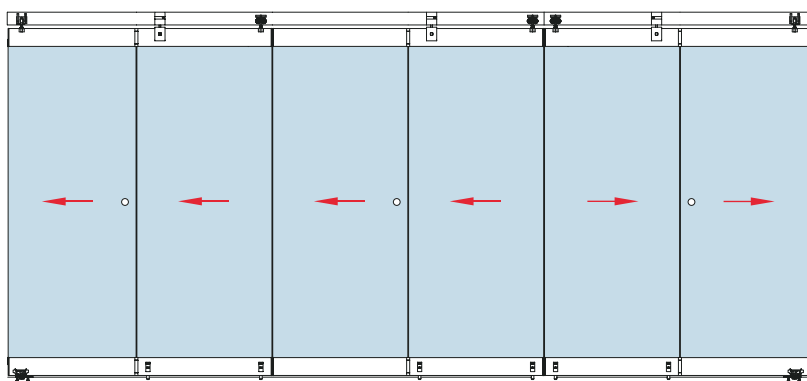

Tip 3a - 6 panouri (4 panouri stanga si 2 panouri dreapta - ca in imaginea alaturata)

Tip 3b - 6 panouri(2 panouri stanga si 4 panouri dreapta)

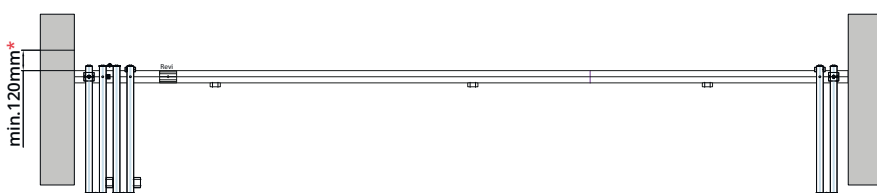

*Distanța minimă structurală(ex - balustrade, scari, etc)

Tip 4

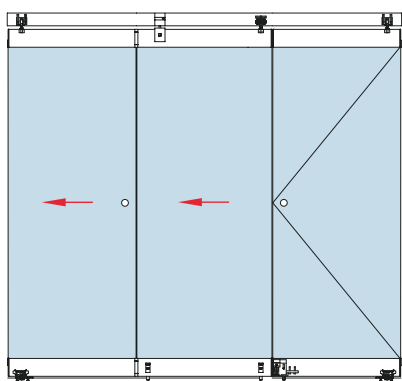

Tip 4a - 2 panouri stanga si 1 usa pivotanta dreapta(ca in imaginea alaturata)

Tip 4b - 2 panouri dreapta si 1 usa pivotanta stanga

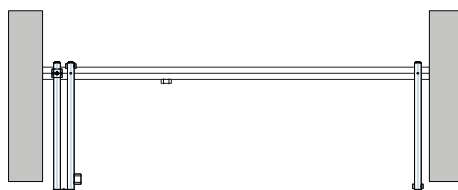

Tip 5

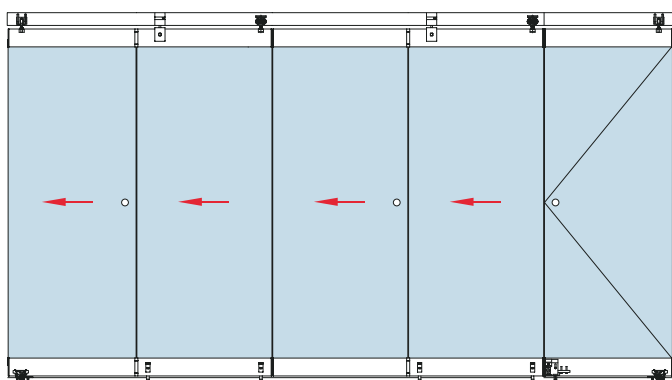

Tip 5a - 4 panouri stanga si 1 usa pivotanta dreapta(ca in imaginea alaturata)

Tip 5b - 4 panouri dreapta si 1 usa pivotanta stanga

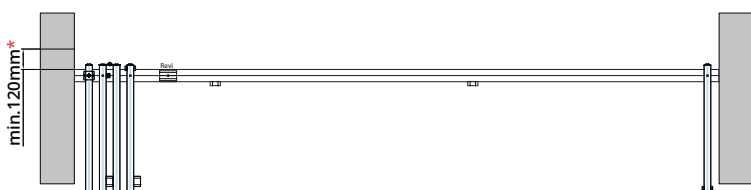

*Distanța minimă structurală(ex - balustrade, scari, etc)